

Wedge-Bolt™ Line Art

---

**Black & White**

**Wedge-Bolt™**

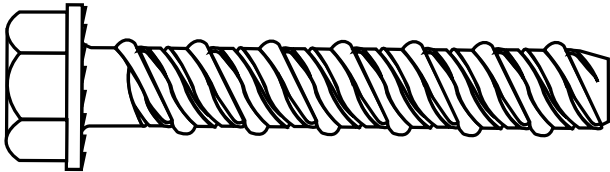

**SDS Max Wedge Bit**



**SDS Plus Wedge Bit**



**HD Straight Shank Wedge Bit**



**Spline Wedge Bit**



**Color**

**Wedge-Bolt™**

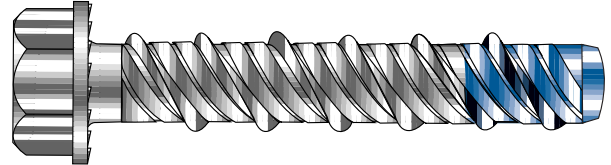

**SDS Max Wedge Bit**



**SDS Plus Wedge Bit**



**HD Straight Shank Wedge Bit**



**Spline Wedge Bit**



## Mechanical Anchoring Products

### Power-Bolt™

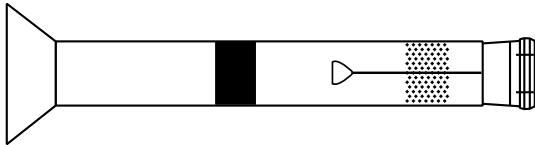
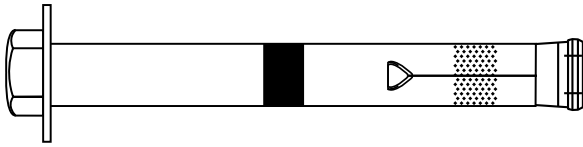

### Power Stud™

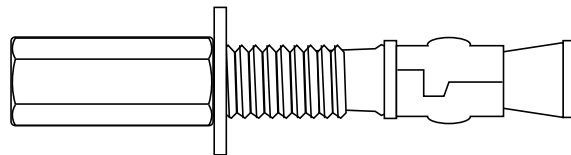
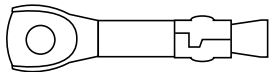
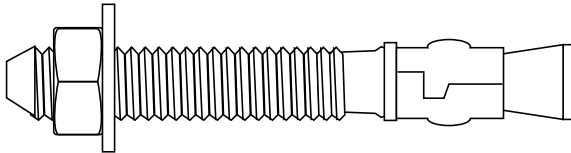

### Set Bolt

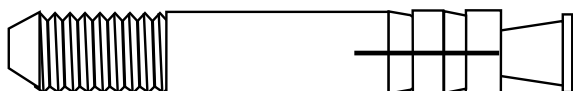

### Lok / Bolt™

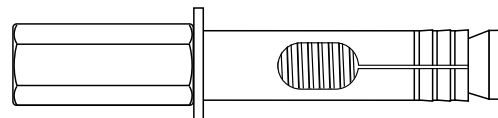
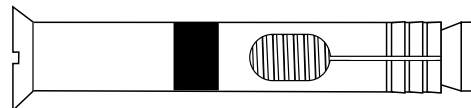
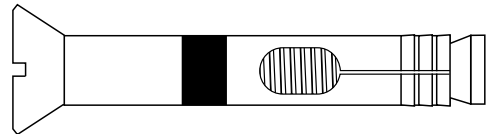
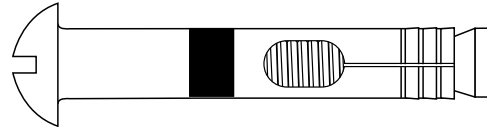
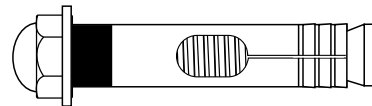
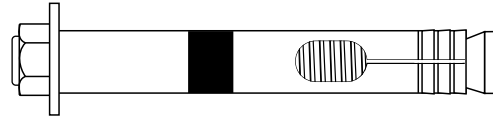

### Lok / Bolt™ Extender

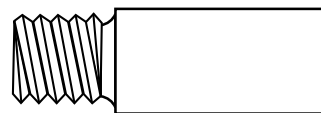

**Rod Coupling**

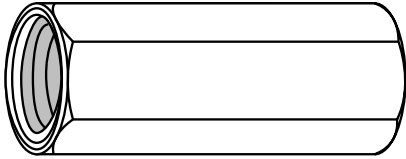

**Steel Drop-In**



**Single**

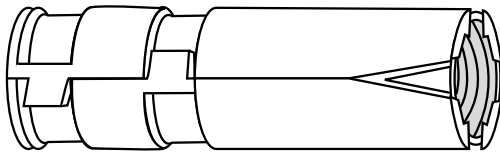

**3/8" Mini Drop-In**

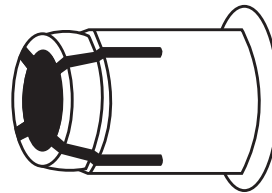

**Double**

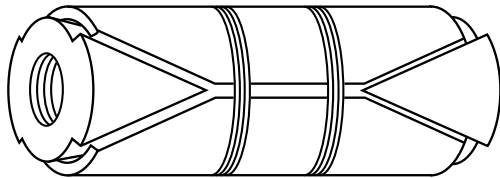

**Coil-Thread Drop-In**

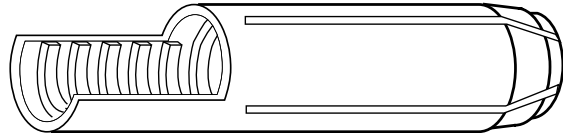

**Calk-In**

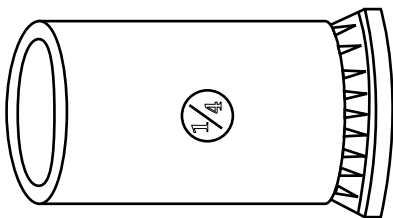

**Hollow Set Drop-In**

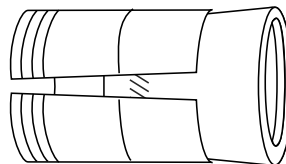

**External Plug Drop-In**



**Lag Shield**

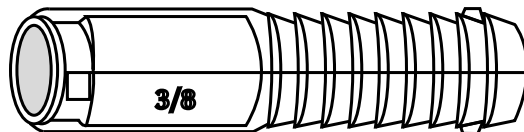

**SPIKE® Anchoring System**

**Mushroom Head SPIKE®**

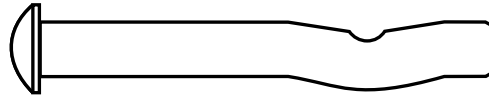

**Threaded SPIKE®**

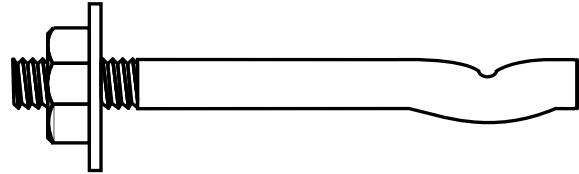

**Flat Head SPIKE®**

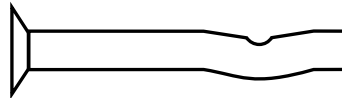

**Pipe SPIKE®**

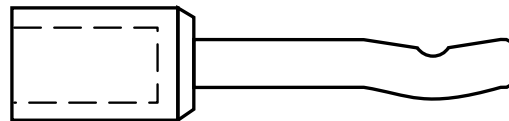

**Tie-Wire SPIKE®**

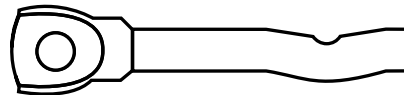

**1000**



**2000**



**3000**



**5000**

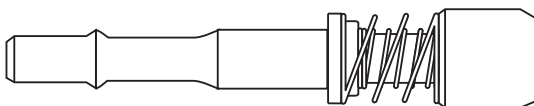

**6000**



**Pipe SPIKE Tool**

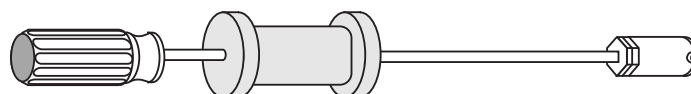

**Puller**

**TAPPER™ Masonry Screw Anchor System**

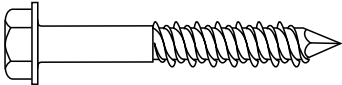
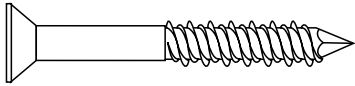

**Perma-Seal® TAPPER™**

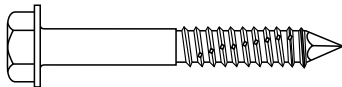
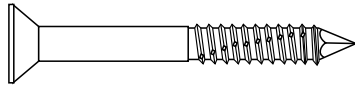

**Type 304 Stainless Steel  
TAPPER™**

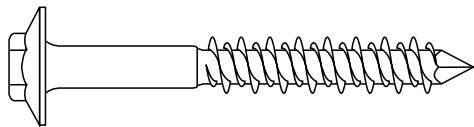
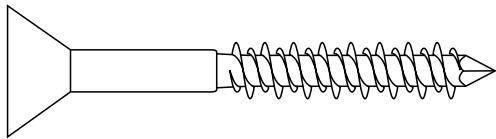

**3/8" Zinc Plated  
Carbon Steel TAPPER™**



**TAPPER™ Straight Shank  
Drill Bit**



**TAPPER™ SDS Drill Bit**

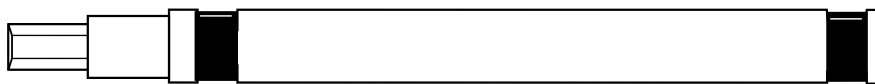

**TAPPER™ 1000 Tool**

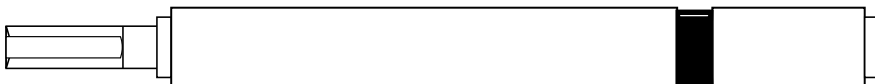

**CONDRIVE® 2000 Tool**

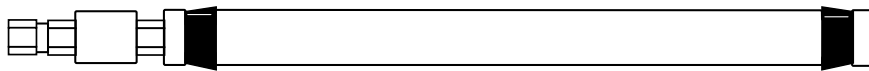

**TAPPER™ 1000 SDS Extension**

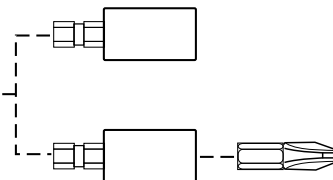

## Mechanical Anchoring Products

### Zamac HAMMER-SCREW® /

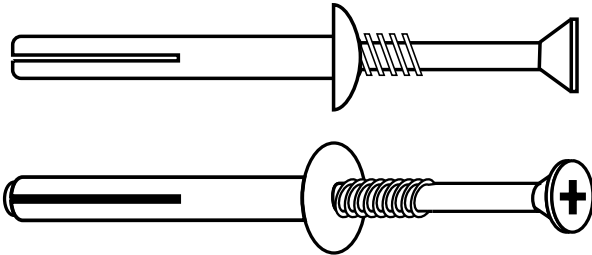

### Drive™

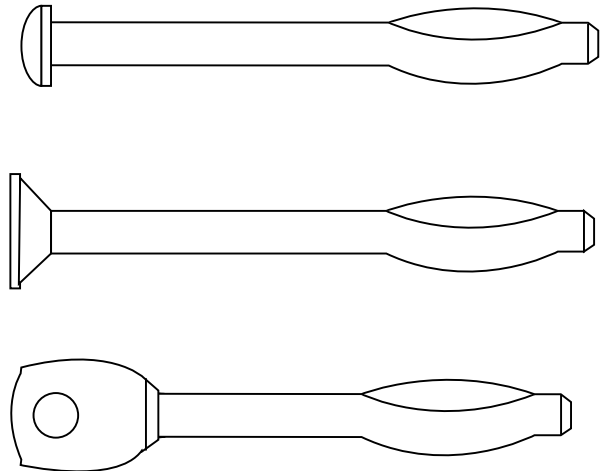

### Zamac Nailin®

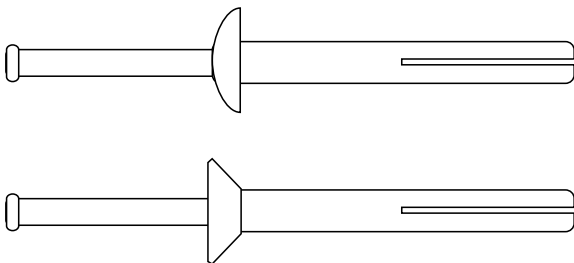

### Bantam Plug

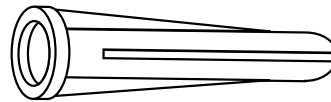

### Scru-Lead

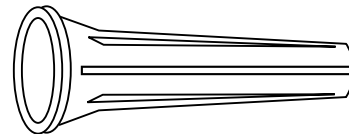

### Nylon Nailin®

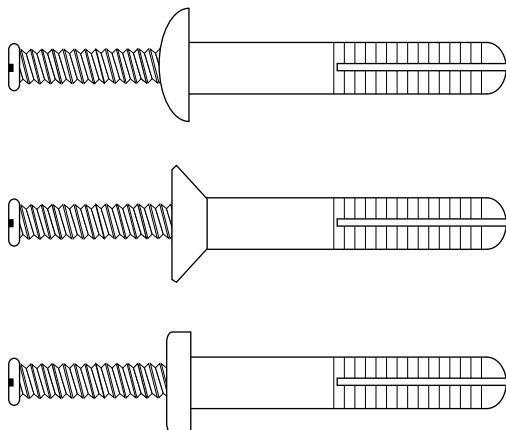

### Fiberplug™

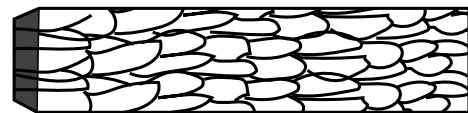

### Fluted Plastic Anchor

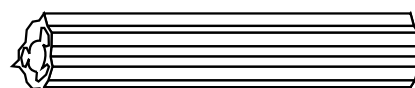

**Hollow Wall Anchoring Products**

**Legs®**

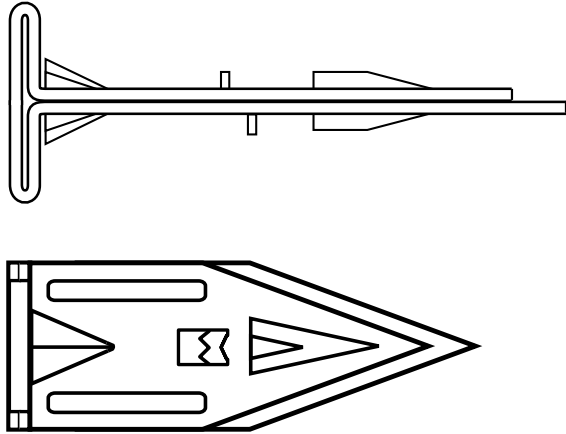

**Poly-Toggle®**

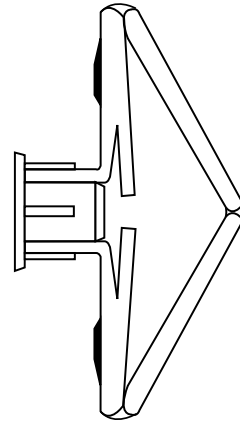

**Standard Polly™**

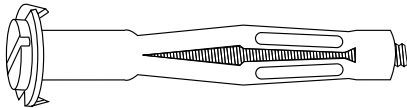

**Drive Polly™**

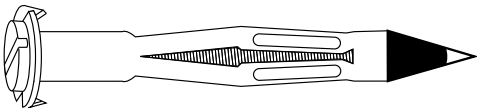

**Nylon ZiP-It®**

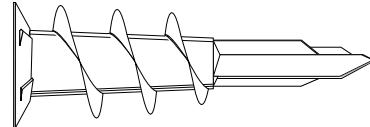

**Zinc ZiP-It®**

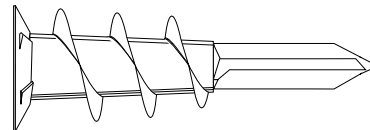

**ZiP-It® Jr.**

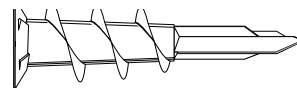

**Polly™ Setting Tool**

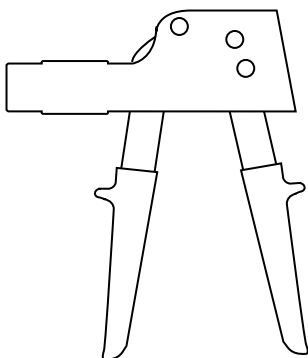

**Hollow Wall Anchoring Products**

**Toggle Bolts**

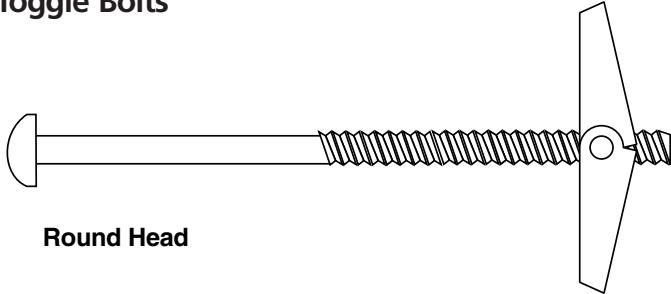

**Round Head**

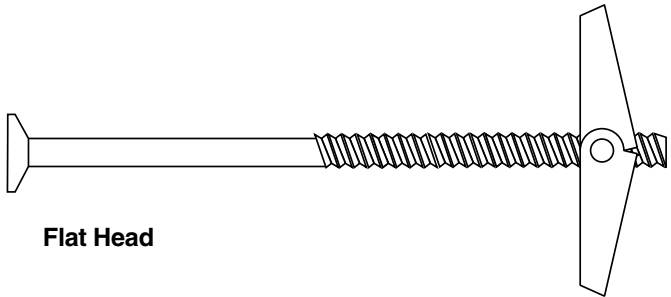

**Flat Head**

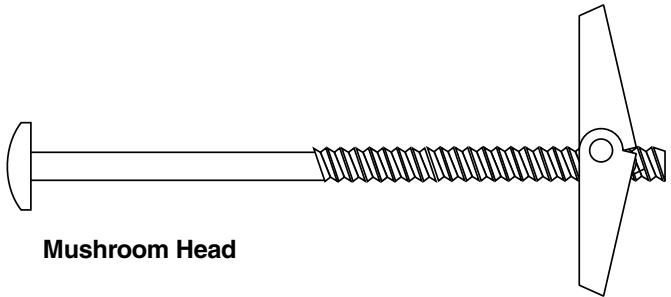

**Mushroom Head**

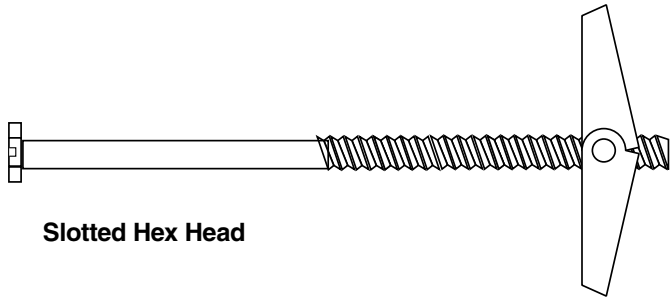

**Slotted Hex Head**

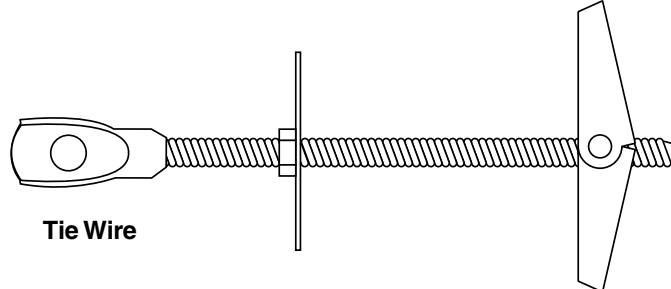

**Tie Wire**

**Twin-Fast**



**Hex Washer Head**

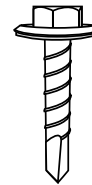

**Hex Washer Head  
with Sealing Washer**

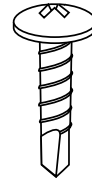

**Phillips Pan Head**



### Power-Fast™

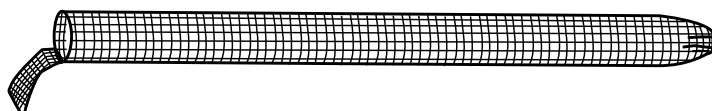
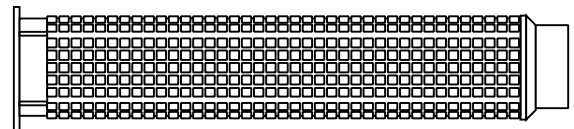
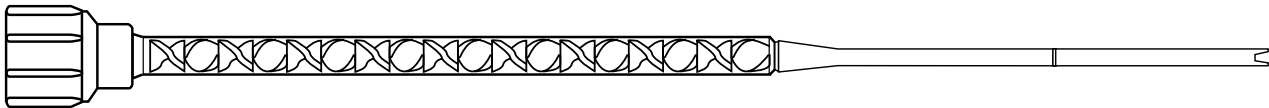
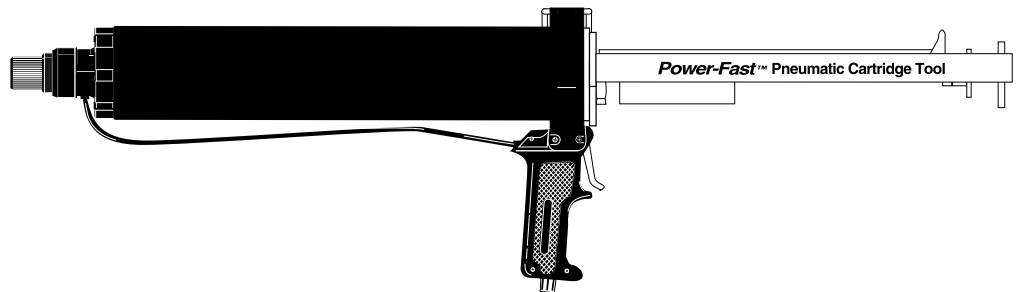
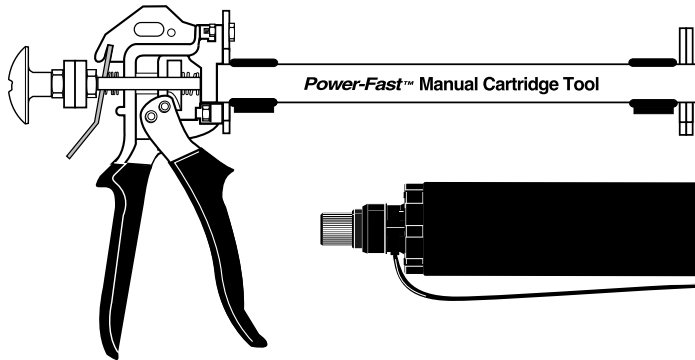
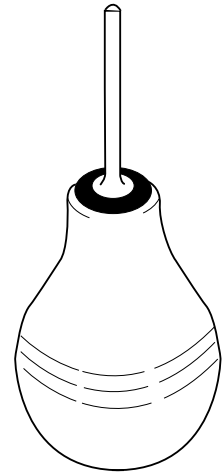
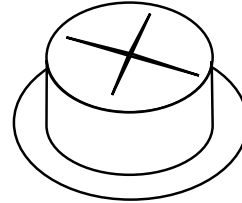
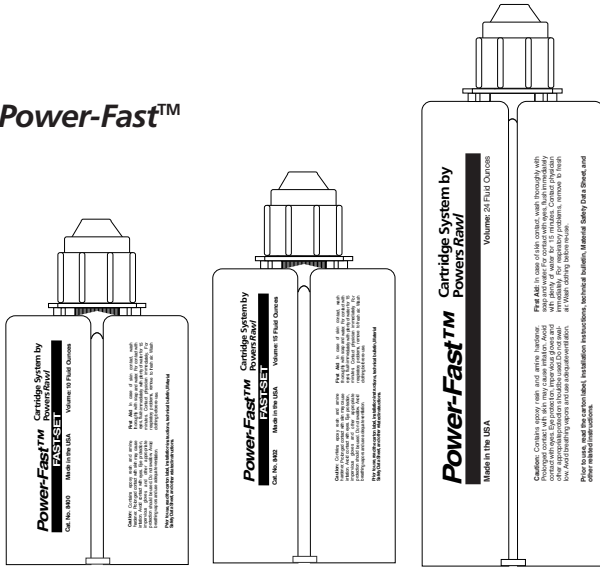

**Adhesive Anchoring Products**

**Chem-Stud**

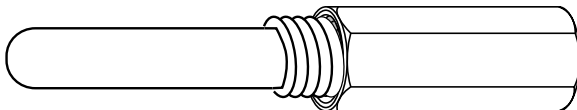
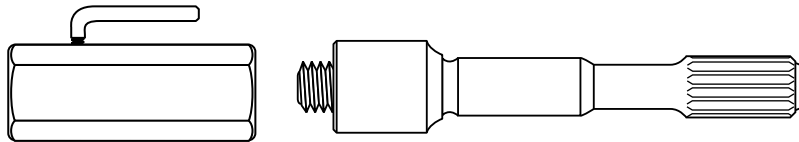
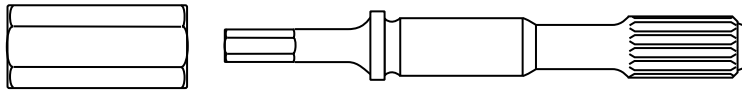
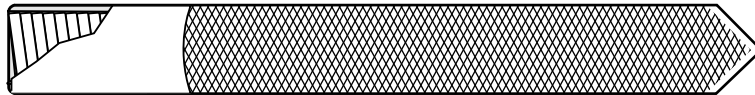
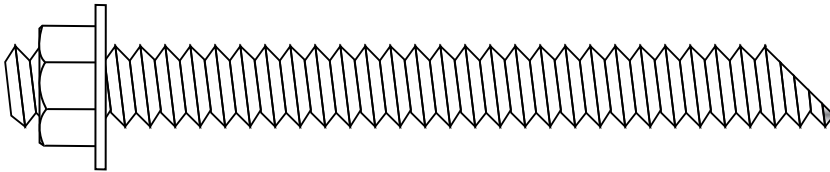
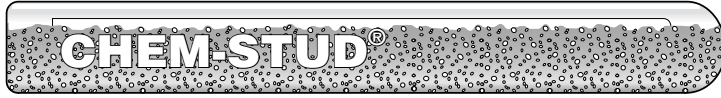

**Chem-Bolt**

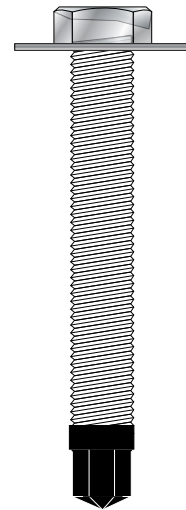

**Hammer-Capsule**



**Adhesive Anchoring Products**

**Power-Bond**



**Chem-Fast II**

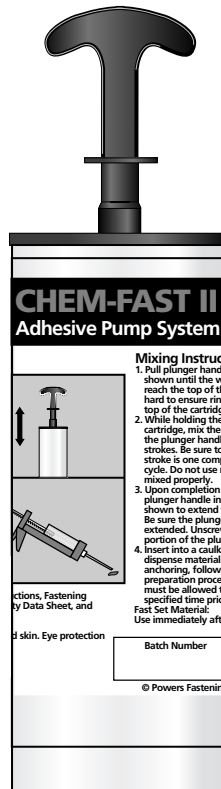

**Acrylic 100**

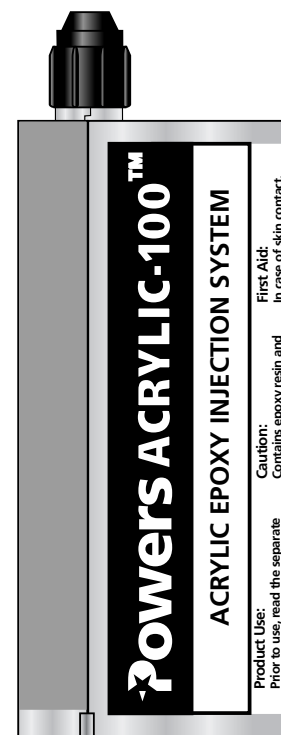

**Roofing Fasteners**

**Deck Screws**



**No. 12 Perma-Seal Deck Screw**

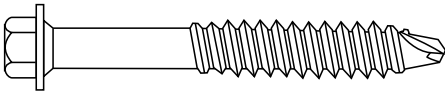

**No. 12 Perma-Seal HWH Deck Screw**

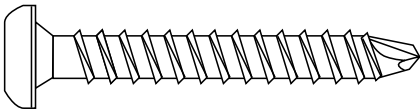

**No. 14 Perma-Seal Deck Screw**



**No. 15 Perma-Seal Deck Screw**

**Roofing SPIKE®**

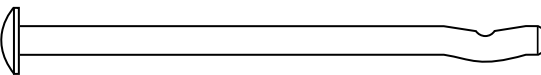

**3/16" SPIKE**

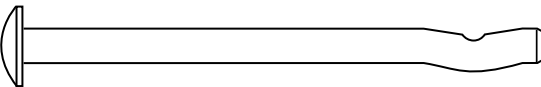

**1/4" SPIKE**

**Stand Up Tool**

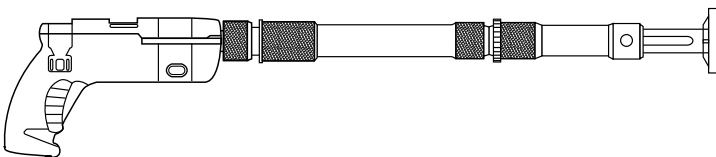

**Stress Plates**

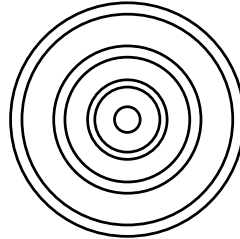

**3" Round Plate**

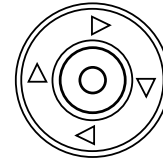

**2" Round Barbed**

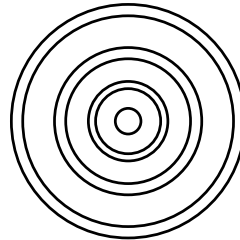

**3" Round Plate (Recessed Head)**

**No. 12 Deck Screws w/Plastic Plate**

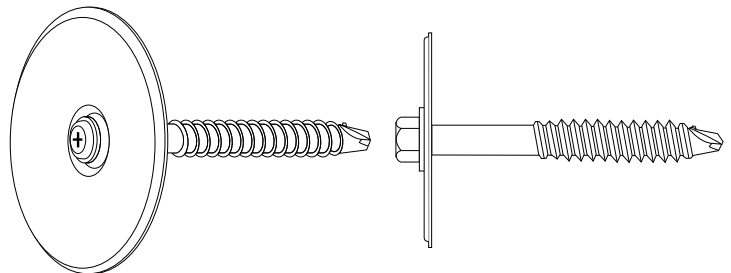

**No. 12 Deck Screws w/Galvalume Plate**

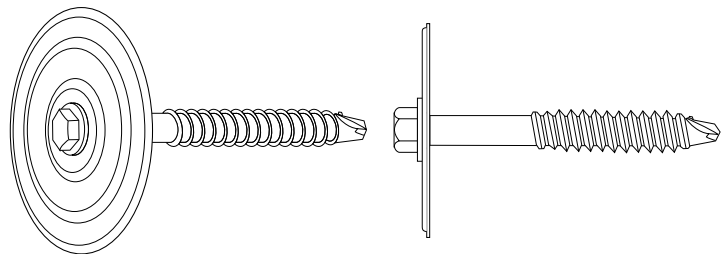

**Speed-Lock® Toggle Bolt**

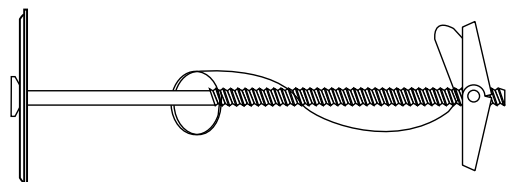

**Roofing Fasteners**

**WOODIE™ / Plates**

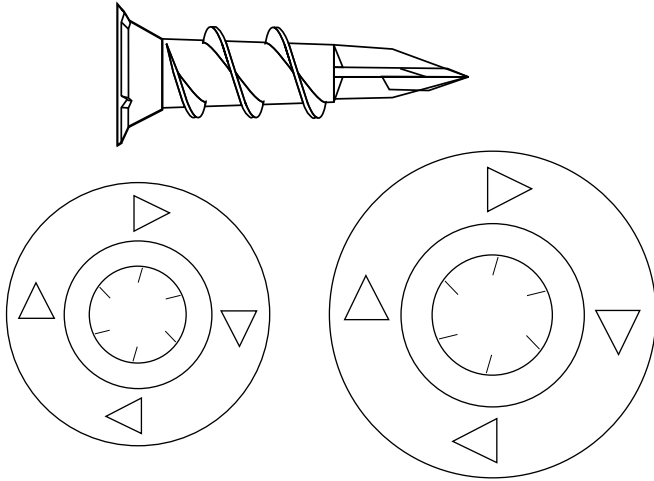

**Powerlite™**

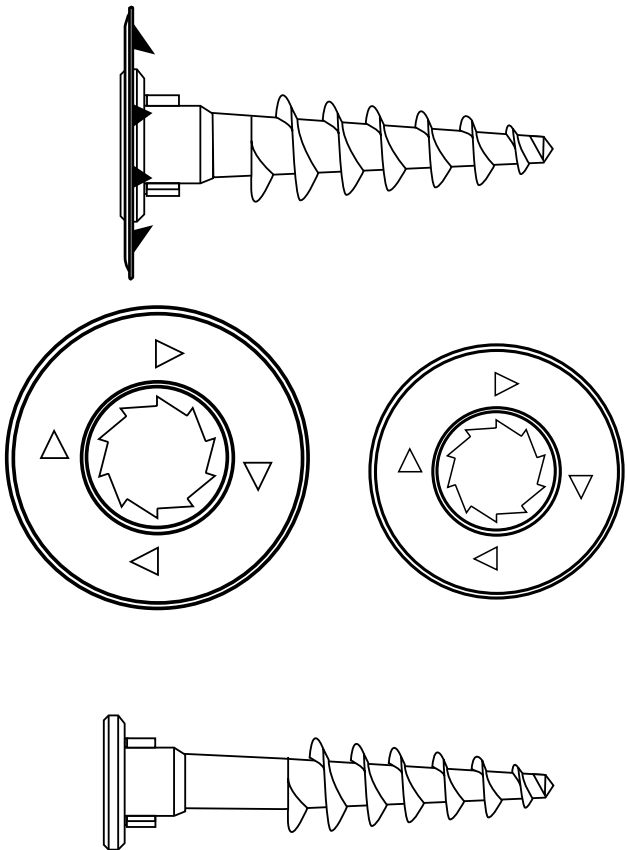

**Carbide Tipped Drill Bits**

---

**SDS-Plus Carbide Drill Bit**



**"A"-Taper Carbide Drill Bit**



**SDS- Max Carbide Drill Bit - Quatro™ Head Design**



**HD Straight Shank Carbide Drill Bit**



**IG Straight Shank Carbide Drill Bit**



**Rotary Carbide Drill Bits**

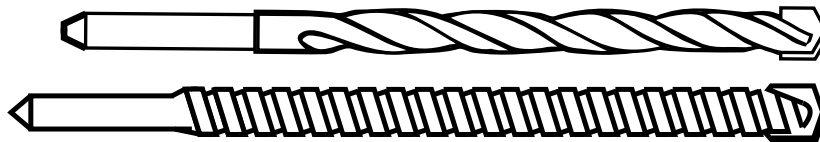

**Spline Carbide Drill Bit**



**SDS-Plus Quatro™ Carbide Drill Bit**



**Carbide Tipped Drill Bits**

---

**Heavy-Duty Chisels**

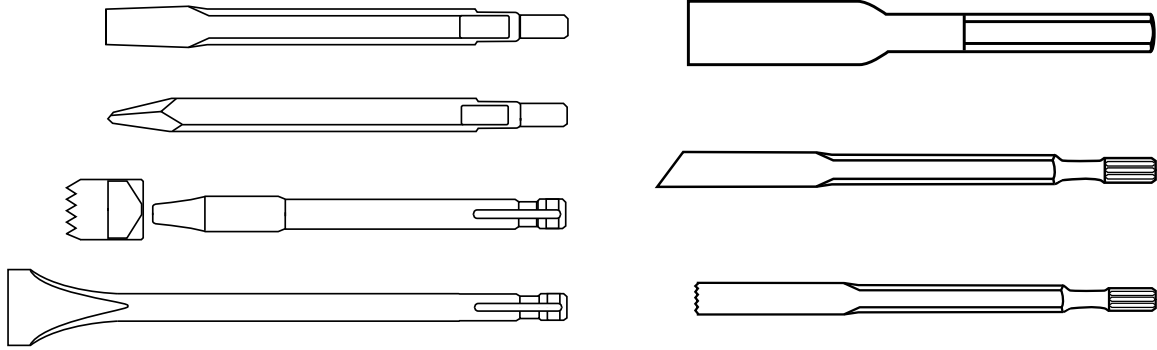

**Concrete Auger Bit**

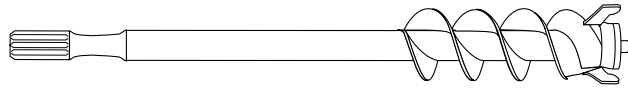

**Heavy-Duty Core Bits**

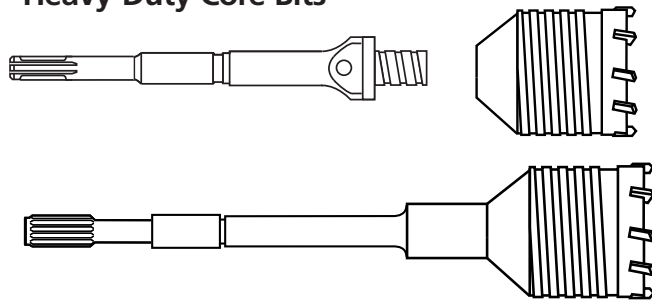

## Powder Actuated Products

**.300 Head Knurled Pins**

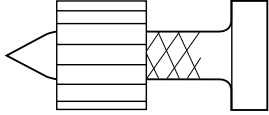

**8mm Head Drive Pin Knurled Pins  
(For steel)**

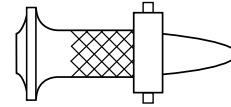

**.300 Head Pins**

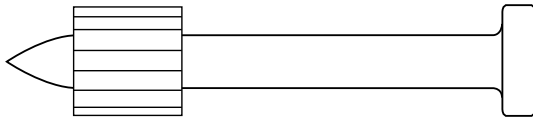

**8mm Head Pins**

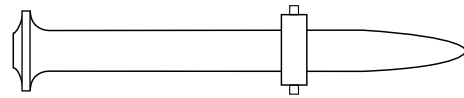

**.300 Head Pins with Washer**

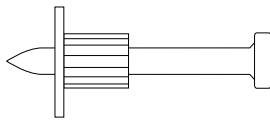

**8mm Head Pins with Washer**

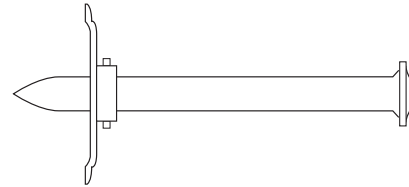

**.300 Head Pins with Insulation Washer**

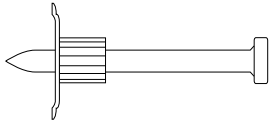

**8mm Head Knurled Top Hat Pins**

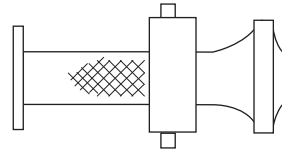

**.300 Head Knurled Top Hat Pins**

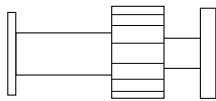

**8mm Head Top Hat Pins**

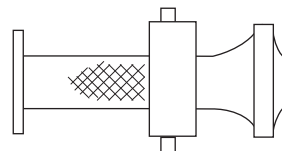

**.300 Head Top Hat Pins**

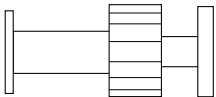

**.300 Head Step Shank Pins**

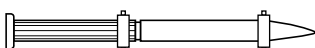



**Powder Actuated Products**

**Assemblies**

**.300 Head Pins with Conduit and BX Cable Straps**

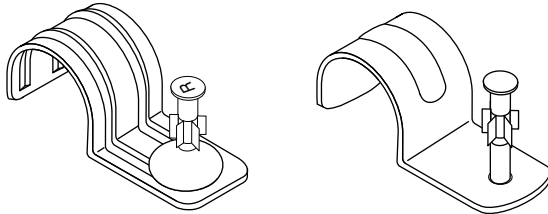

**8mm Head Drive Pins with Conduit Straps**

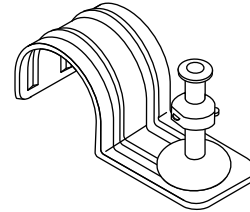

**.300 Head Pins with Ceiling Clips**

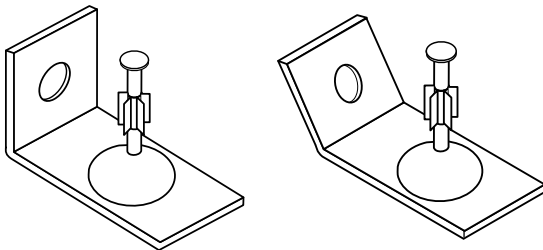

**8mm Head Drive Pins with Ceiling Clips**

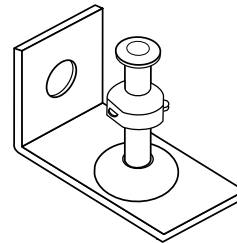

**Ladd Pin and Clip**

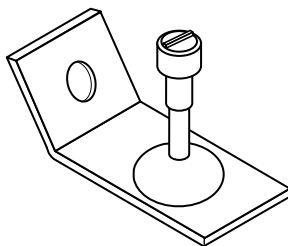

**Rebar Basket Clips**

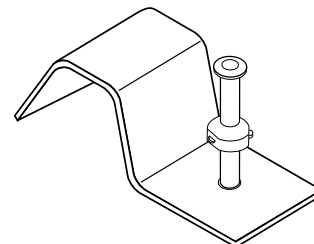

## Powder Actuated Products

---

### Forming Pin

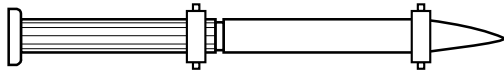

### 3/8" Head Drive Pins

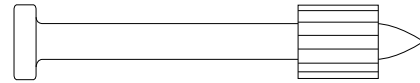

### 6mm Head Drive Pins

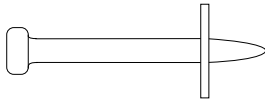

### Step Shank

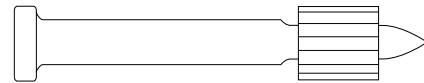

### 1/4" Threaded Studs Knurled (for steel)

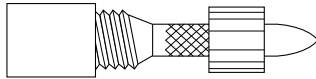

### 1/4" Hammer Drive Pins

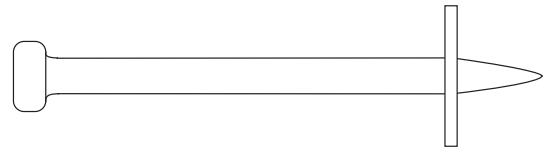

### 1/4" Threaded Studs (for Concrete)

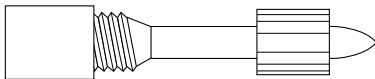

(Not for use in Powder Actuated Tools.)

### 3/8" Threaded Studs Knurled (for steel)

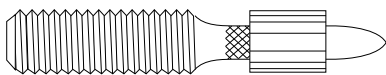

### 3/8" Threaded Studs (for Concrete)

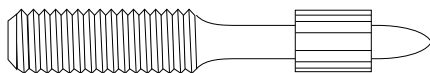

## Powder Actuated Products

### Loads

**.22 Caliber "A" Neck Down**

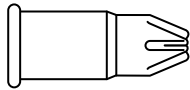

**.22 Caliber Ladd**

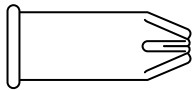

**.25 Caliber Disc**

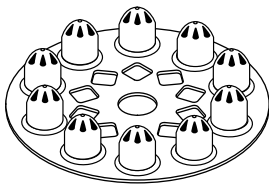

**.25 Caliber International Disc**

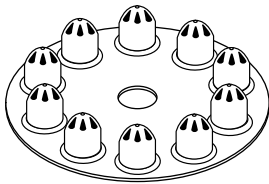

**.25 Caliber Single**

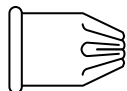

**.25 Caliber Strip**

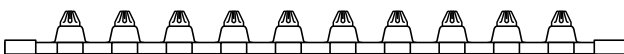

**.27 Caliber long**

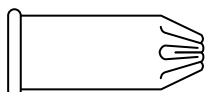

**.27 Caliber Single**

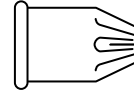

**.27 Caliber Strip**

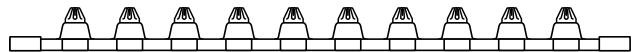

**.27 Caliber Strip (Purple)**



**.27 Caliber Safety Strip**



**.27 Caliber Clear-Fire™ Lead-Free Safety Strip**



**R7200**

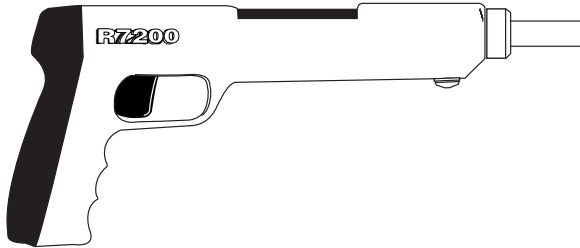

**R35S**

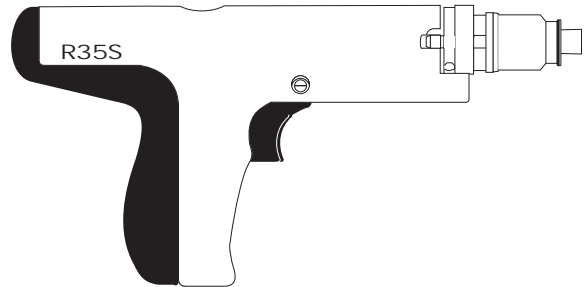

**R2200**

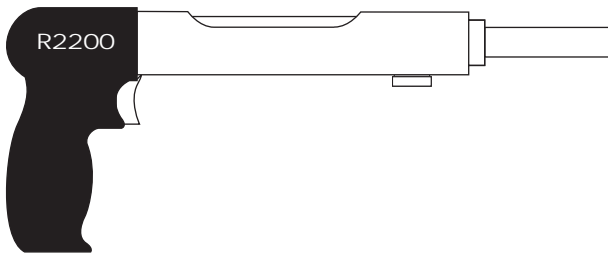

**R3500**

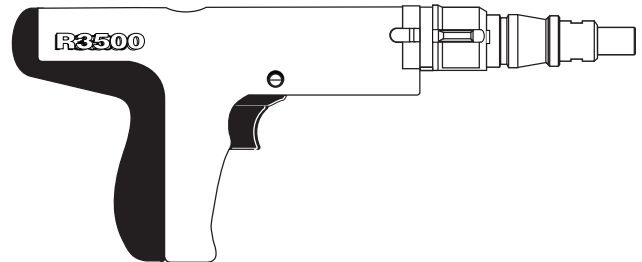

**Powers**  
FASTENERS

**Powers**  
FASTENERS

**Powers**  
FASTENERS

**Powers**  
FASTENERS

**Powers**  
FASTENERS

**Powers**  
FASTENERS

**Powers**  
FASTENERS

**Powers**  
FASTENERS

**Powers**  
FASTENERS

**Powers**  
FASTENERS

**Powers**  
FASTENERS